

Features :

- Suitable for redundant operation of 24V system
- Installed on DIN Rail TS35 / 7.5 or 15
- Relay contact signal output and LED indicator for input failure alarm
- Cooling by free air convection
- 2 year warranty



MODEL	IEDV-RD20	
OUTPUT	REVERSE VOLTAGE (max.)	30V
	OUTPUT CURRENT (max.)	20A
	VOLTAGE DROP	0.5V
	LED INDICATORS	Two green LEDs indicating each input is "OK or fail"
INPUT	INPUT VOLTAGE RANGE	21 ~ 28V
	NUMBER OF INPUTS	Two
	INPUT CURRENT (max.)	20A per input
FUNCTION	INPUT VOLTAGE ALARM	When input is < 20V(±5%) or > 30V(±5%) relay contacts
	RELAY CONTACT RATING (max.)	30VDC, 1A
ENVIRONMENT	WORKING TEMP.	-20 ~ 70°C
	WORKING HUMIDITY	20 ~ 90% RH non condensing
	STORAGE TEMP., HUMIDITY	-40 ~ +85°C, 10 ~ 95% RH
	VIBRATION	10~500Hz, 2G 10min. / 1cycle, period for 60min. each along X,Y, Z axes ; Mouning: Compliance to IEC60068-2-6
SAFETY & EMC	WITHSTAND VOLTAGE	Terminal-Chassis :0.5KVAC, Relay Contacts-Terminal :0.5KVAC
	ISOLATION RESISTANCE	Terminal-Chassis :>100M Ohms / 500VDC 25°C 70%RH
	EMI CONDUCTION & RADIATION	Compliance to EN55022 (CISPR22) Class B
	EMS IMMUNITY	Compliance to EN61000-4-2,3,4,5,6,8, ENV50204, Heavy industry level,criteriaA
OTHERS	MTBF	MIL-HDBK-217F (25°C)
	DIMENSION	55.5*125.2*100mm (W*H*D)
	PACKING	20pcs / 11Kg / 1.29CUFT
NOTE	All parameters NOT specially mentioned are measured at 24VDC input, rated load and 25°C of ambient temperature.	

Mechanical Specification

ADMISSIBLE DIN-RAIL:TS35/7.5 ORTS35/15

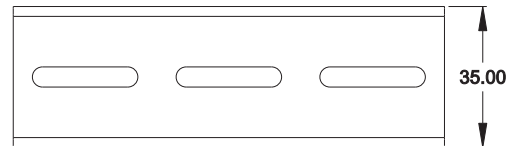
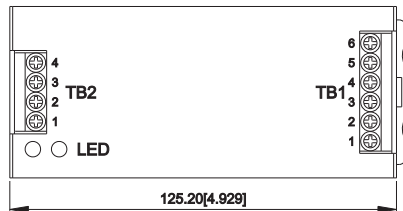

Terminal Pin No.Assignment (TB1)

Pin NO.	Assignment
1	Vout+
2	Vout-
3,4	Vin-
5	Vin B+
6	Vin A+

Terminal Pin No.Assignment (TB2)

Pin NO.	Assignment
1	Alarm B1
2	Alarm B2
3	Alarm A1
4	Alarm A2

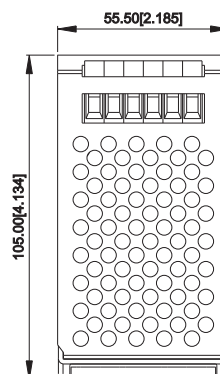
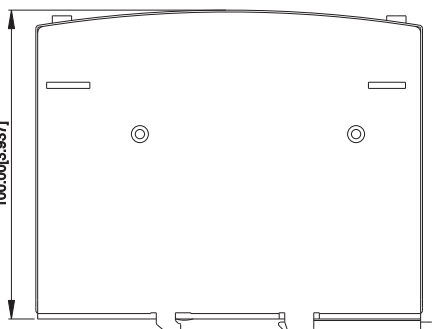
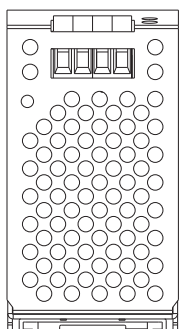

Typical Application Notes :

a. 1+1 Redundancy:

Using 1 more PSU as the redundant unit

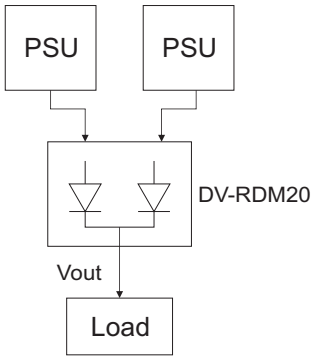

b. 1+N Redundancy:

Using more PSUs as the redundant units to increase the reliability

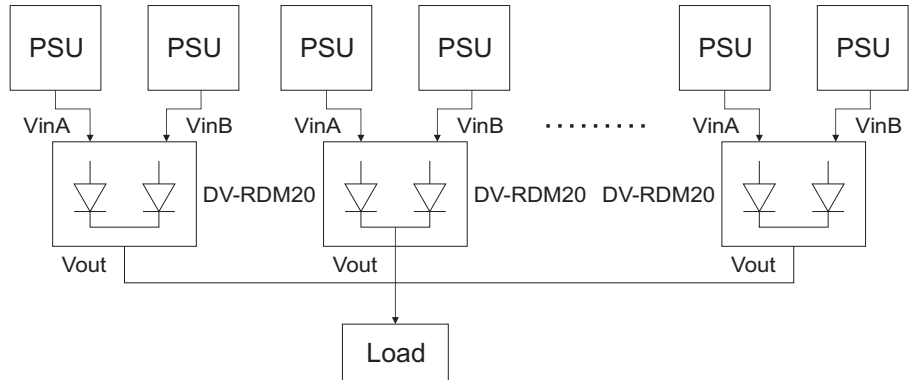

c. Single Use:

Connecting only one PSU to one SD-RDM20 to reduce the stress of the diodes and hence increase the reliability

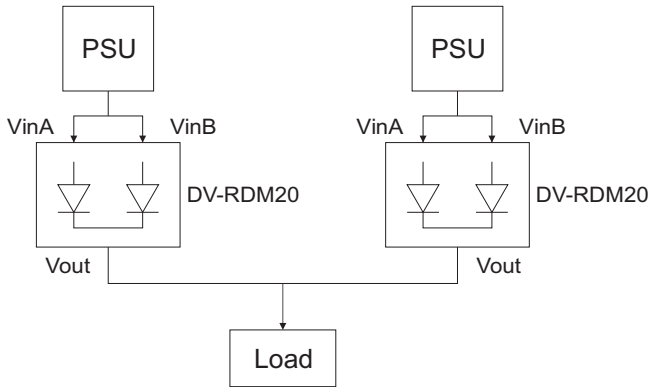

Block Diagram

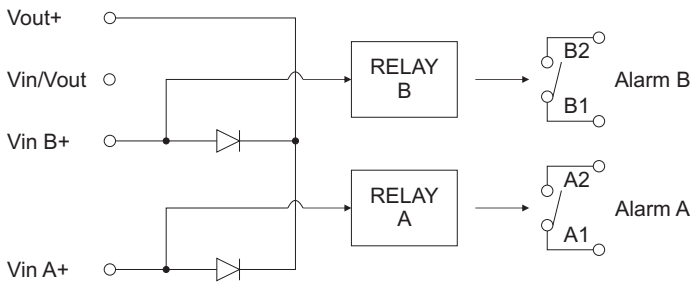

Derating Curve

