



User Manual

SR250A/SR500A/SR750A

AC/DC POWER SUPPLY & FLOAT CHARGER (for lead acid batteries)

**Model Codes:**

SR250A/SR500A/SR750A
SR250D/SR500D/SR750D
SR250L/SR500L/SR750L

SR250P
SR250M

- = Standard
- = Standard with alarms
- = 'D' version with extra output alarm (LV versions only for SR500L and S750L)
- = 'D' version with built-in output diode (24V & above)
- = for use with OVP input protection units

1. INTRODUCTION

The **SR250A-750A** range is designed for use as a very accurate AC to DC power supply, or float charger for lead acid batteries. Note that for float charging the output voltage must be set to approximately 15% above the nominal battery voltage. This is done as the default voltage for the 12V model but must be specified at time of order for all higher voltage models.

2. CONNECTIONS

If used as a float charger always connect the positive output of the power supply to the positive terminal of the battery. The charger may be permanently connected to float charge lead acid batteries but it is essential to periodically check the electrolyte level of flooded cells as there is always some evaporation.

Where screw/plug in terminals are fitted (eg. SR500A24FXL), and there are two terminals provided for each polarity, both terminals must be used. This is to ensure that the current rating of the terminal block is not exceeded.

CONNECTION LAYOUT

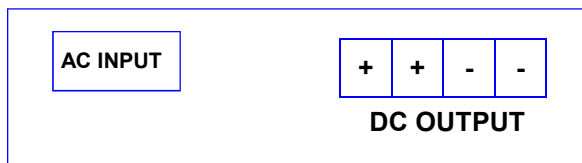

Screw Conn. Output

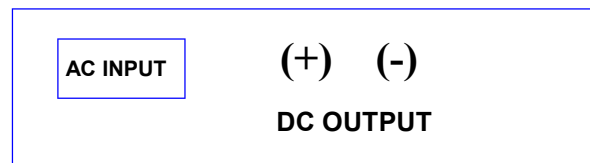

Stud Conn. Output

3. LED INDICATION CODES

3.1 -A Standard version

*1 **POWER OK** LED indicates DC present on output terminals (either from PSU or battery, if connected)

MODE	LED INDICATION	
	POWER OK* ¹	STANDBY
DC PRESENT	ON	OFF
DC ABSENT	OFF	OFF
STANDBY	As above	ON

3.2 -D Alarm version

MODE	LED INDICATION		
	DC OK* ²	POWER OK* ³	STANDBY
NORMAL	ON	ON	OFF
DC LOW* ⁴	OFF	ON	OFF
STANDBY	As above	OFF	ON

*2 **DC OK** LED indicates DC output is present, either from PSU or battery (if connected)

*3 **POWER OK** LED indicates input power on (unless there is a short circuit on the output)

*4 **DC LOW** settings as in para. 3.3

3.3. -L Alarm version (with DC high alarm)

DC OK LED: *Slow flash:* **DC LOW** **Settings:** PSU: 0.83 xVnom. **Charger:** 1.83V/cell
Fast flash: **DC HIGH** **Settings:** PSU: 1.2 x Vnom **Charger:** 2.5V/cell

4. ALARM TERMINAL LAYOUT (for -D & -L*⁵ versions):

DC HIGH * ⁵			MAINS FAIL			DC OK			FG
COM	NC	NO	COM	NC	NO	COM	NC	NO	

Relay contacts shown in **de-energised** state (ie when there is a fault condition).
 Alarm relays are **energised** when power supply is operating normally.

*⁵ No **DC HIGH** alarm relay fitted on HV versions, eg. **SR500L92, SR750L92**

5. INPUT CONNECTIONS FOR DC INPUT MODELS

BROWN : POSITIVE +
 BLUE: NEGATIVE -
 GREEN/YELLOW: EARTH

6. FG (Frame Ground)

Where provided, this terminal provides a connection to the metal case for an earthing point.

7. STANDBY FUNCTION

Pushing the **STANDBY** button turns the output of the power supply off. If there is a battery connected, the **DC OK** LED remains on even though the power supply is turned off (except for -P versions with output diode)



*Ideal as a Standby Float Charger
for lead acid batteries*

- Industrial quality AC/DC power supply
- Standalone - bench top or fixed mounting
- Front panel controls & indication
- Suitable for float charging of lead acid batteries
- Optional serial communications port, SR250L
- Optional relay alarm outputs - model SR250D,P
- Conservative design for long life
- Optional DC input
- Precise voltage and current control
- Efficient switch mode design
- Suitable for parallel operation
- Optional temperature compensation for charging
- ISO9001 design management system

◆ 24 Month Warranty

SPECIFICATIONS All specifications are typical at nominal input, full load and at 20°C unless otherwise stated.

ELECTRICAL

Input - standard	180-264 or 88-132V, 45-65Hz (internal link select)
- option	110VDC (99 -150) or 220VDC(180-270) (specify at time of order if DC input required)
Fusing	Internal input fuse
Overcurrent Protection	Constant current limit under overload and short circuit conditions
OVP	Over-voltage protection on output at ~ 130% of nominal output voltage
Thermal Protection	Yes, self resetting
Isolation	1KV DC input - output / earth
Efficiency	≥ 85%
Inrush current	Soft start circuit
Output Power	250W
Output Voltages	Refer to model table
Voltage adj. range	85 - 115% of Vout
Line Regulation	<0.2% over AC input range
Load Regulation	<0.4% open circuit to 100% load
Noise	<1%
Drift	0.03% / °C
Hold-up time	15 - 20 ms without battery

PHYSICAL

AC Input connector	IEC320 socket
DC Connections	M6 brass stud or plug-in socket with screw terminals
Enclosure	Zinc plated steel /powder coated lid
Dimensions	150W x 61H x 242D (excl. terminals)
Weight	1.7 Kg
Indication LEDs	Standard: Power OK, Standby With alarms: DC OK, Power OK, Standby
Alarm relay output (option)	C - NO - NC changeover rated 1A /50V DC, 32VAC
Standby Mode	Turns off DC output of PSU

ENVIRONMENTAL

Operating temperature	0 - 50 °C ambient at full load De-rate linearly >50 °C to no load @ 70 °C
Storage temperature	-10 to 85 °C ambient
Humidity	0 - 95% relative humidity non-condensing
Cooling	24V & above: natural convection 12V: fan cooled

STANDARDS

EMI	To CISPR 22 / EN55022 class A
Safety	To IEC950 / EN60950 / AS/NZS3260

ACCESSORIES SUPPLIED

Mounting feet together with screws
AC power cord 1.5m with IEC320 socket and NZ/Aust plug
Mating screw-terminal plug for alarm outputs
Crimp lugs for stud terminal versions
DC screw terminal plug-in connector for 'X' version

250 Watt AC/DC Stand Alone Power Supply/Float Charger

SR250A

incl. SR250D, SR250L, SR250P

STANDARD MODEL TABLE

MODELS	Power Supply		Battery Charger		Adjustable range (V)
	Output Volts (factory default)	Output Current (A) (continuous)	Output Volts* (Charging)	Output Current (A) (Charging)	
SR250A7.5	7.5	20	6.9	20	6.8-8
SR250A12	13.8	18.1 @13.8V	13.8	18.1	11-14
SR250A24	24	10.4	27.6	9.0	22-28
SR250A30	30	8.3	34.5	7.2	28-36
SR250A36	36	6.9	41.4	6.0	34-43
SR250A48	48	5.2	55.2	4.5	45-57
SR250A60	60	4.1	69.0	3.6	54-66

* Please specify on ordering if the unit is to be used for float charging (except for 12V model which is set at 13.8V by default).

OPTIONS

Temperature Compensation for charging	Temperature sensor on 1.7m lead with adhesive pad: -4mV / °C / cell ±10% Order Code: +TEMPCO
Alarms (SR250D..)	<ul style="list-style-type: none"> Mains/PSU fail (or PSU in standby mode) DC low (Battery low or PSU low) - set at 92% of nominal voltage. Special version available: Battery low alarm operates when mains power is on, order code: SFMCT-OA v1.1
Extra DC Fault Alarm (SR250L..)	Alarm level to be specified at time of order, eg. DC high
Alarm Relay Contacts	C - NO - NC full changeover rated 1A /50V DC, 32VAC
Internal output diode (SR250P..)	Incl. alarms & output diode for N+1 redundancy, internal diode not available for 12V models.
Earth Fault Alarm (external)	Detects leakage to earth of DC output and provides relay output Order Code: +ALARM/EFDM (20-60V)
If external surge suppressor fitted	Replace end suffix -L with -M (230VAC input version) internal MOV is rated at higher voltage than external surge suppressor

OPTIONAL COMMUNICATION PORT - SR250L....

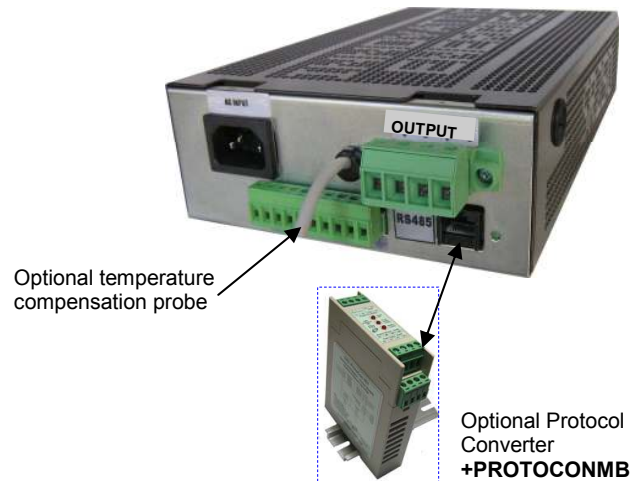

- Includes three relay alarm outputs
- Serial (RS232 or RS485) or ethernet port
- SNMP protocol or ASCII code
- Optional MODBUS protocol converter for use with RS485
- Example of code: **SR250L12FSL-LAN+** (for SNMP model)

MODEL IDENTIFICATION CODES

SR250A12 T F S L-485

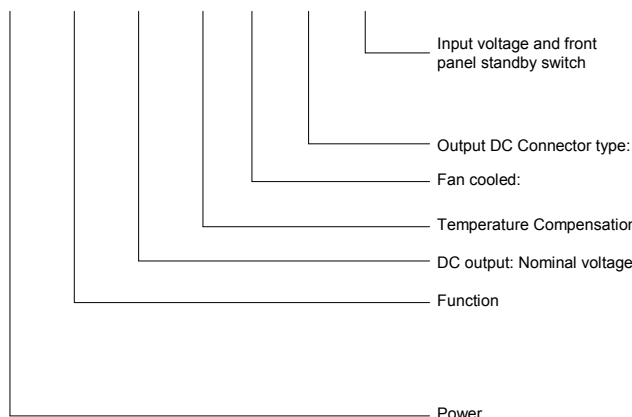

Optional communication port for SR250L versions	485 = RS485 LAN + = Ethernet (SNMP)	232 = RS232 LAN = Ethernet (ASCII)
L = 230V AC + switch	Blank = 230V AC no switch	G = 110V AC no switch
U = 110V AC + switch	H = 110V DC + switch	J = 110V DC no switch
M = 230V AC + switch + 300V MOV (to be used with IEOVPHVAC)	K = motorhome version (please refer to separate data sheet)	
S = Stud	X = Plug in /screw terminal block	
F = Fan	Blank = No fan	
T = Yes	Blank = No	
12, 24, 30, 36, 48, 60		
A = Standard PSU	D = Standard with alarms	
L = D version with extra DC fault alarm and optional comms port	P = D with output diode for parallel redundancy (>24V only)	
250W		



Optional internal V/I
meter shown

*Ideal as a Standby Float Charger
for lead acid batteries*

- Industrial quality AC/DC power supply
- Standalone - bench top or fixed mounting
- Front panel controls & indication
- Suitable for float charging of lead acid batteries
- Suitable for parallel operation
- Conservative design for long life
- Precise voltage and current control
- Optional temperature compensation for charging
- Optional relay alarm outputs
- Optional DC input
- Optional communications port: RS232, RS485 or ethernet
- Optional protocols available: Modbus, SNMP or ASCII code

◆ 24 Month Warranty

SPECIFICATIONS All specifications are typical at nominal input, full load and at 20°C unless otherwise stated.

ELECTRICAL

Input - standard - option	180V - 264V, 45-65Hz 88V - 132VAC 45-65Hz
Fusing	Internal input fuse
Overload protection	Constant current limit under overload and short circuit conditions (except DC input versions which have primary current limit)
Isolation	1KV DC input - output / earth
Over voltage protection	130% of nominal output voltage
Efficiency	≥ 85%
Inrush current	Soft start circuit
Output power	500W
Output voltage	Refer to model table
Line regulation	<0.2% over AC input range
Load regulation	<0.4% open circuit to 100% load
Noise	<1%
Drift	0.03% / °C
Hold-up time	15 - 20 ms without battery
Thermal protection	Yes, self resetting
Parallel operation	Yes
- higher power	Addition of external output diodes optional
- N+1 redundancy	Use SR500D... with external output diodes

PHYSICAL

AC input connector	IEC320 inlet socket
DC connections	M8 brass stud or plug in/screw terminal block
Alarm connections	Plug-in screw terminal block
Enclosure	Powder coated steel
Dimensions	225W x 70H x 304D mm (excl. terminals)
Weight	4.3 Kg
Indication LEDs	Standard: Power OK, Standby With alarms: DC OK, Power OK, Standby
Standby switch	Turns off DC output of PSU

ENVIRONMENTAL

Operating temperature	0 to + 50 °C ambient at full load De-rate linearly >50 °C to no load @ 70 °C
Storage temperature	-10 to 85 °C ambient
Humidity	0 - 95% relative humidity non-condensing
Cooling	Fan cooled

STANDARDS

EMI	To CISPR 22 / EN55022 class A
Safety	To IEC950 / EN60950 / AS/NZS3260

ACCESSORIES SUPPLIED

Mounting feet together with screws
AC power cord 1.5m with IEC320 socket and NZ/Aust plug
Mating screw-terminal plug for alarm outputs
Crimp lugs for stud terminal versions
DC screw terminal plug-in connector for 'X' version

500 Watt AC/DC Stand Alone Power Supply/Float Charger

SR500A

incl. SR500D, SR500L

STANDARD MODEL TABLE

MODELS	Power Supply		Battery Charger		Adjustable range (V)
	Output Volts (factory default)	Output Current (A)	Output Volts* (Charging)	Output Current (A) (Charging)	
SR500A12	13.8	36.2 (41.6 @ 12V)	13.8	36.2	11-14
SR500A24	24	20.8	27.6	18.2	22- 29
SR500A30	30	16.6	34.5	14.5	28-36
SR500A36	36	13.8	41.4	12.0	34-43
SR500A48	48	10.4	55.2	9.1	45-57
SR500A91	96	5.2	110	4.5	90-115
SR500A92	108	4.6	124	4.0	100-130
SR500A93	120	4.1	138	3.6	110-145

* Please specify on ordering that unit is to be used for float charging (except for 12V model which is set at 13.8V by default).



Rear view of SR500D....or SR500L... with alarm contacts and no communication port option

OPTIONS

Temperature compensation for charging	Temperature sensor on 1.7m lead with adhesive pad: -4mV / °C / cell ±10% Order Code: +TEMPCO
Alarms - SR500D..	<ul style="list-style-type: none"> • Mains fail (or PSU in standby mode) • DC low (Battery low or PSU low) <ul style="list-style-type: none"> - Charger: set at 1.83V/cell - PSU: set at 83% V out
- SR500L..	<ul style="list-style-type: none"> • As SR500D.. + DC high alarm (NB: no alarm relay fitted on HV versions, only LED indication)
Alarm contacts	C - NO - NC changeover rated 1A /50V DC, 32VAC
DC Input	110VDC (99-150) or 220VDC (180-270) Please note that an external fuse or MCB must be fitted on the output for short circuit protection.
Earth fault alarm (external to PSU)	Detects leakage to earth of DC output and provides relay output Code: +ALARM/EFDM (20-60V) +ALARM/EFDH (61-150V)

OPTIONS

Communications Port	Choice of RS485, RS232, ethernet (SNMP or ASCII) Available on SR500L... models
Internal V/I meter	Add code: +INT-METER
Mounting options:	
19" rack mount	2U sub rack available, Code: SR-RM2U Optional V/I meter, Code: SR-METER
Wall mount enclosure	PSU may be fitted into enclosure with MCBs and terminals. Code: SEC-SR

MODEL IDENTIFICATION CODES

SR500A 12 T F S L-LAN

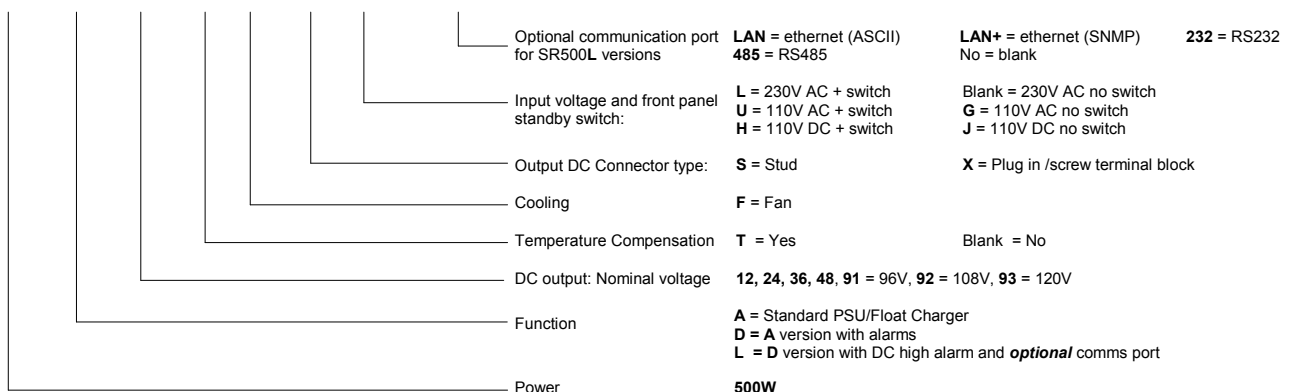



Optional internal V/I
meter shown

*Ideal as a Standby Float Charger
for lead acid batteries*

- Industrial quality AC/DC power supply
- Standalone - bench top or fixed mounting
- Front panel controls & indication
- Suitable for float charging of lead acid batteries
- Suitable for parallel operation
- Conservative design for long life
- Precise voltage and current control
- Optional temperature compensation for charging
- Optional relay alarm outputs
- Optional DC input
- Optional communications port: RS232, RS485 or ethernet
- Optional protocols available: Modbus, SNMP or ASCII code

◆ 24 Month Warranty

SPECIFICATIONS All specifications are typical at nominal input, full load and at 20°C unless otherwise stated.

ELECTRICAL

Input - standard - option	230VAC (180 - 264), 45-65Hz 110VAC (88 - 132), 45-65Hz
Fusing	Internal input fuse
Overload protection	Constant current limit under overload and short circuit conditions (except DC input versions which have primary current limit)
Isolation	1KV DC input - output / earth
Over voltage protection	130% of nominal output voltage
Efficiency	≥ 85%
Inrush current	Soft start circuit
Output power	750W
Output voltage	Refer to model table
Line regulation	<0.2% over AC input range
Load regulation	<0.4% open circuit to 100% load
Noise	<1%
Drift	0.03% / °C
Hold-up time	15 - 20 ms without battery
Thermal protection	Yes, self resetting
Parallel operation	Yes
- higher power	Addition of external output diodes optional
- N+1 redundancy	Use SR750D... with external output diodes

PHYSICAL

AC input connector	IEC320 inlet socket
DC connections	M8 brass stud or plug in/screw terminal block
Alarm connections	Plug-in screw terminal block
Enclosure	Powder coated steel
Dimensions	225W x 70H x 304D mm (excl. terminals)
Weight	4.3 Kg
Indication LEDs	Standard: Power OK, Standby With alarms: DC OK, Power OK, Standby
Standby switch	Turns off DC output of PSU

ENVIRONMENTAL

Operating temperature	0 to + 50 °C ambient at full load De-rate linearly >50 °C to no load @ 70 °C
Storage temperature	-10 to 85 °C ambient
Humidity	0 - 95% relative humidity non-condensing
Cooling	Fan cooled

STANDARDS

EMI	To CISPR 22 / EN55022 class A
Safety	To IEC950 / EN60950 / AS/NZS3260

ACCESSORIES SUPPLIED

Mounting feet together with screws
AC power cord 1.5m with IEC320 socket and NZ/Aust plug
Mating screw-terminal plug for alarm outputs
Crimp lugs for stud terminal versions
DC screw terminal plug-in connector for 'X' version

750 Watt AC/DC Stand Alone Power Supply/Float Charger

SR750A

incl. SR750D, SR750L

STANDARD MODEL TABLE

MODELS	Power Supply		Battery Charger		Adjustable range (V)
	Output Volts (factory default)	Output Current (A) (continuous)	Output Volts* (Charging)	Output Current (A) (Charging)	
SR750A12	13.8	54 (54 @ 11-14V)	13.8	54	11-14
SR750A24	24	31.2	27.6	27	22- 29
SR750A30	30	25	34.5	21.7	28-36
SR750A36	36	20.8	41.4	18	34-43
SR750A48	48	15.6	55.2	13.6	45-57
SR750A91	96	7.8	110	6.8	90-115
SR750A92	108	6.9	124	6.0	100-130
SR750A93	120	6.2	138	5.4	110-145

* Please specify on ordering that unit is to be used for float charging (except for 12V model which is set at 13.8V by default).



Rear view of SR750D...or SR750L... with alarm contacts and no communication port option

OPTIONS

Temperature compensation for charging	Temperature sensor on 1.7m lead with adhesive pad: -4mV / °C / cell ±10% Order Code: +TEMPCO
Alarms - SR750D..	<ul style="list-style-type: none"> • Mains fail (or PSU in standby mode) • DC low (Battery low or PSU low) <ul style="list-style-type: none"> - Charger: set at 1.83V/cell - PSU: set at 83% V out
- SR750L..	<ul style="list-style-type: none"> • As SR750D.. + DC high alarm (NB: no alarm relay fitted on HV versions, only LED indication)
Alarm contacts	C - NO - NC changeover rated 1A /50V DC, 32VAC
DC Input	110VDC (99-150) or 220VDC (180-270) Please note that an external fuse or MCB must be fitted on the output for short circuit protection.
Earth fault alarm (external to PSU))	Detects leakage to earth of DC output and provides relay output Code: +ALARM/EFDM (20-60V) +ALARM/EFDH (61-150V)

OPTIONS (continued)

Communications port	Choice of RS485, RS232, ethernet (SNMP or ASCII) Available on SR750L... models
Internal V/I meter	Add code: +INT-METER
Mounting options:	
19" rack mount	2U sub rack available, Code: SR-RM2U Optional V/I meter, Code: SR-METER
Wall mount enclosure	PSU may be fitted into enclosure with MCBs and terminals. Code: SEC-SR

MODEL IDENTIFICATION CODES

SR750A 12 T F S L-LAN

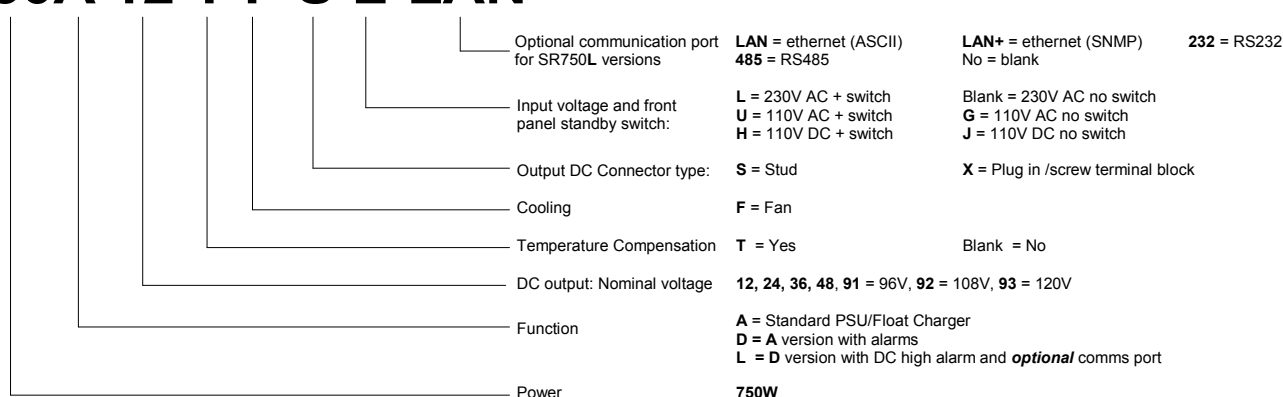

CONNECTION FOR PARALLEL REDUNDANCY

Two or more **SRxxxA**, **SRxxxD** or **SRxxxL** power supplies may be connected in parallel for increased power or parallel redundancy. Figure 1 below shows two **SR xxx D** units connected with external diodes. It is essential that the wiring from each unit to the load is kept identical for equal power sharing particularly when diodes are not used.

Diodes can be fitted inside some power supplies (see models listed below). The **SRxxxP** series identifies when an internal diode is fitted in the power supply. Figure 2 shows two **SRxxxP** units connected in parallel.

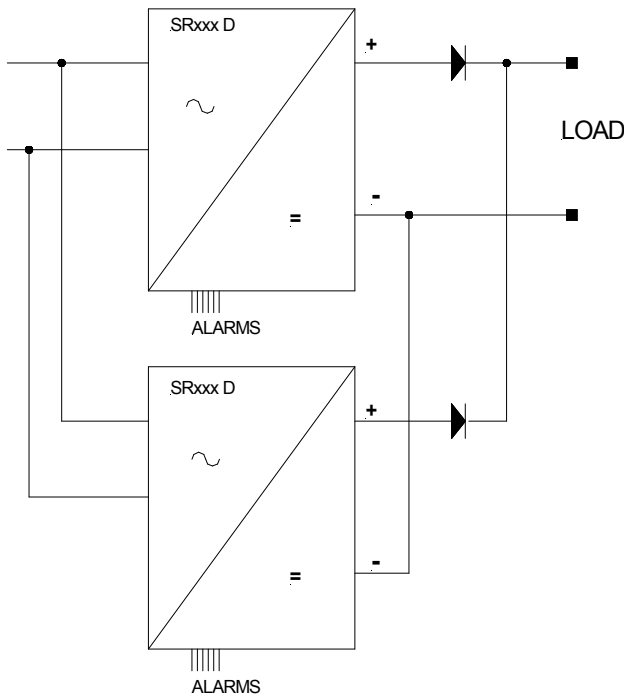

Fig. 1: Two SRxxx D with external diodes

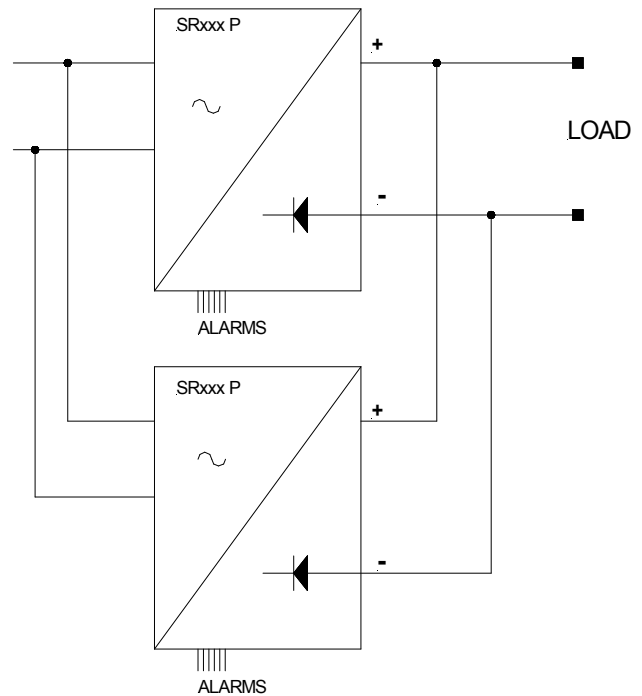

Fig. 2: Two SRxxx P connected in parallel

INTERNAL diodes (in negative leg) can be fitted to the following models only:

100W: SR100P24, SR100P36, SR100P48

250W: SR250P24, SR250P30, SR250P36, SR250P48, SR250P60

All other models have diodes external to the power supply, eg fitted into a 2U rack as shown in the photo to the right.



2U rack with 2 x SR250D12 power supplies and decoupling diodes on heatsink plus V/I meter

Safety

The user is responsible for ensuring that input and output wiring segregation complies with local standards and that in the use of the equipment, access is confined to operators and service personnel. A low resistance earth connection is essential to ensure safety and additionally, satisfactory EMI suppression (see below).

HAZARDOUS VOLTAGES EXIST WITHIN A POWER SUPPLY ENCLOSURE AND ANY REPAIRS MUST BE CARRIED OUT BY A QUALIFIED SERVICEPERSON.

Electrical Strength Tests

Components within the power supply responsible for providing the safety barrier between input and output are constructed to provide electrical isolation as required by the relevant standard. However EMI filtering components could be damaged as result of excessively long high voltage tests between input, output and ground. Please contact our technicians for advice regarding electric strength tests.

Earth Leakage

The EMI suppression circuits causes earth leakage currents which may be to the maximum allowable of 3.5mA.

Ventilation

High operating temperature is a major cause of power supply failures, for example it has been well documented that a 10°C rise in the operating temperature of a component will halve its expected life. Therefore always ensure that there is adequate ventilation for the equipment. Batteries and cooling fans also suffer shortened lifetimes if subjected to high ambient temperatures - both should be included in a routine maintenance schedule to check for signs of reduced efficiency.

Water / Dust

Every effort must be made in the installation to minimise the risk of ingress of water or dust. Water will almost always cause instant failure. The effects of dust are slower in causing failure of electronic equipment but all electrical equipment should be cleaned free of any dust accumulation at regular intervals. This is particularly important where internal fans are fitted.

Electromagnetic Interference (EMI)

Switching power supplies and converters inherently generate electrical noise. All wiring should be as short as practicable and segregated from all equipment wiring which is sensitive to EMI. Residual noise can be reduced by looping DC wiring through ferrite cable sleeves. These are most effective as close to the power supply as possible and as many turns of the wire taken through the core (+ and - in the same direction) as the core will accommodate.

Fuse ratings

Check that the wiring and fuses or MCBs match the rating of the PSU or converter. Adequate fuse protection of battery circuits is very important owing to the large potential currents available from batteries.

Connection polarity

It is critical to check the polarity carefully when connecting DC power supplies and chargers to equipment. Boost chargers and some float chargers usually have reverse polarity protection (RPP), which can be electronic (non-destructive) or by an internal fuse which needs to be replaced if a battery is connected in reverse.

Glossary of terms used in our user manuals

PSU = power supply unit

BCT = battery condition test

ECB = electronic circuit breaker

ELVD = electronic low voltage disconnect

RPP = reverse polarity protection

EMI = electromagnetic interference

SNMP = Simple Network Management Protocol

LAN = local area network

DOD = depth of discharge

DIMENSIONS FOR SR250

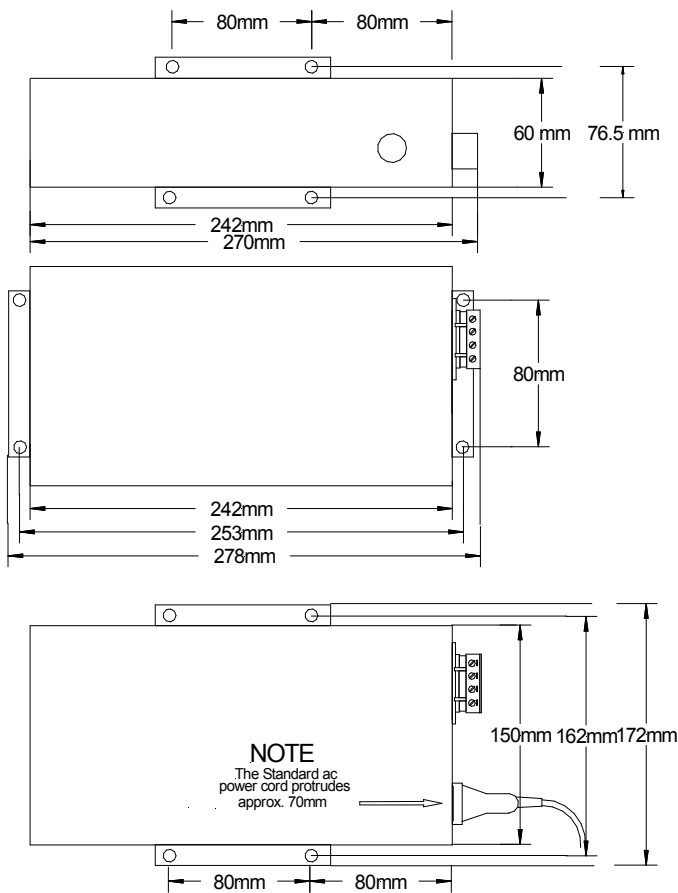

Fig. 1: Plug in/ screw terminal connectors

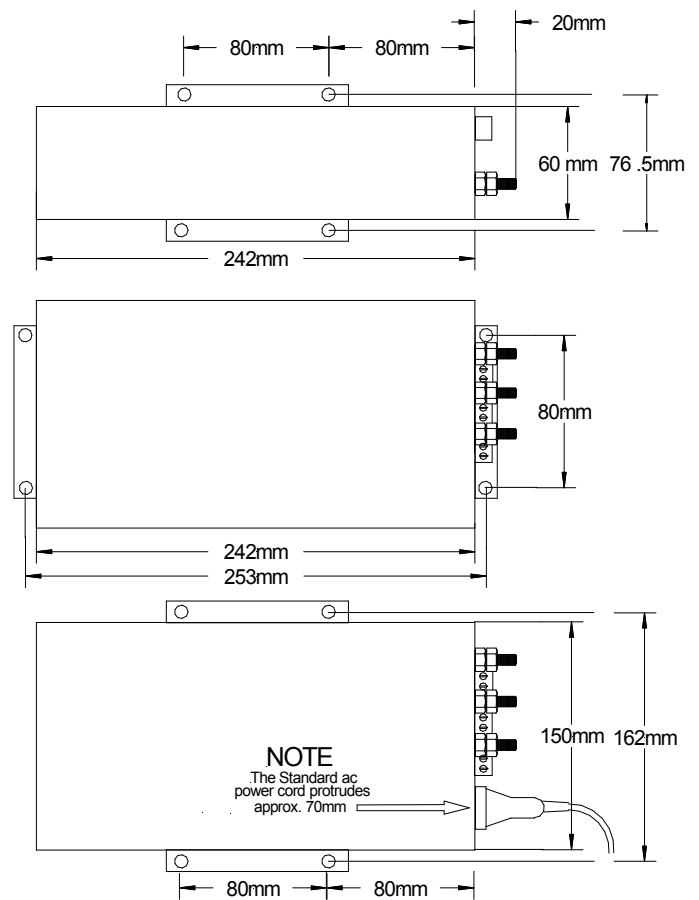

Fig. 2: Stud connectors

TERMS OF WARRANTY

Innovative Energies Ltd warrants its power supplies for 24 months (two years) from date of shipment against material and workmanship defects.

Innovative Energies' liability under this warranty is limited to the replacement or repair of the defective product as long as the product has not been damaged through misapplication, negligence, or unauthorized modification or repair.

Innovative Energies Limited

Phone: +64 9 835 0700
 Fax: +64 9 837 3446
 Email: info@innovative.co.nz
 Online: www.innovative.co.nz
 In Person: 1 Heremai Street, Henderson, Auckland, NZ
 Post: PO Box 19501, Auckland 1746, NZ