

◆ 24 Month Warranty

- Choice of RS485, RS232 or LAN connection
- SNMP available using LAN connection
- Optional Modbus protocol converter available for use with RS485 output
- Connect Modbus output to existing PLC or Scada system
- Remote live monitoring of output voltage, battery & PSU current, battery temperature, alarm conditions
- 9 alarm state signals / 4 command functions
- Remote enable/disable/initiation of battery condition test
- Programming port for initial setup & local monitoring using PC
- BCT (battery condition test) may be enabled or disabled by user

SPECIFICATIONS: Please refer to: 1. SR100C, SR250C data sheets for full specifications on power supplies.
2. +PROTOCONMB data sheets for full specifications on protocol converters.

1. Block schematic for RS232/ LAN

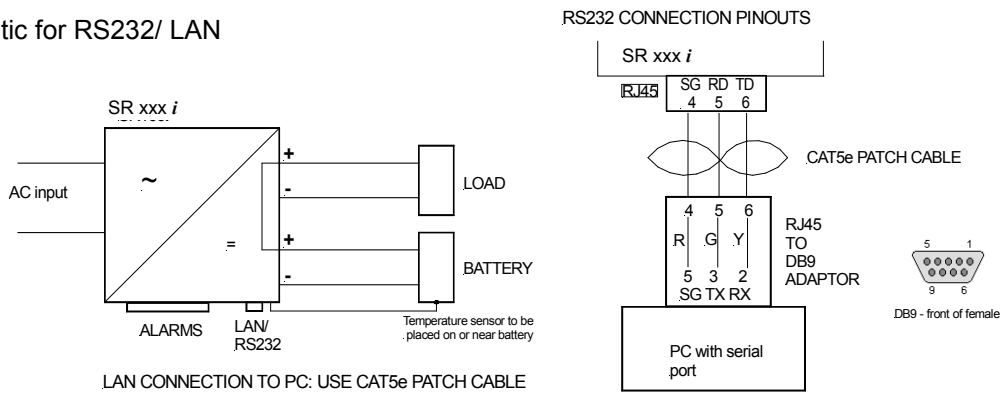

2. Block schematic for RS485 with protocol converter

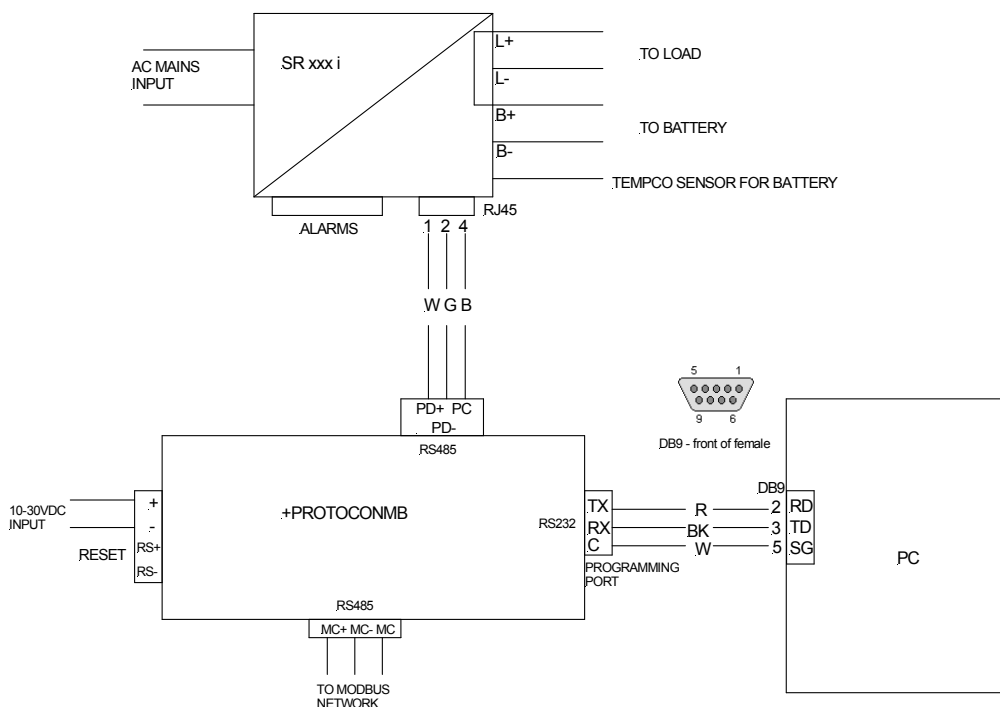

100 W & 250W No-Break™ DC UPS with comms. port

SR... i

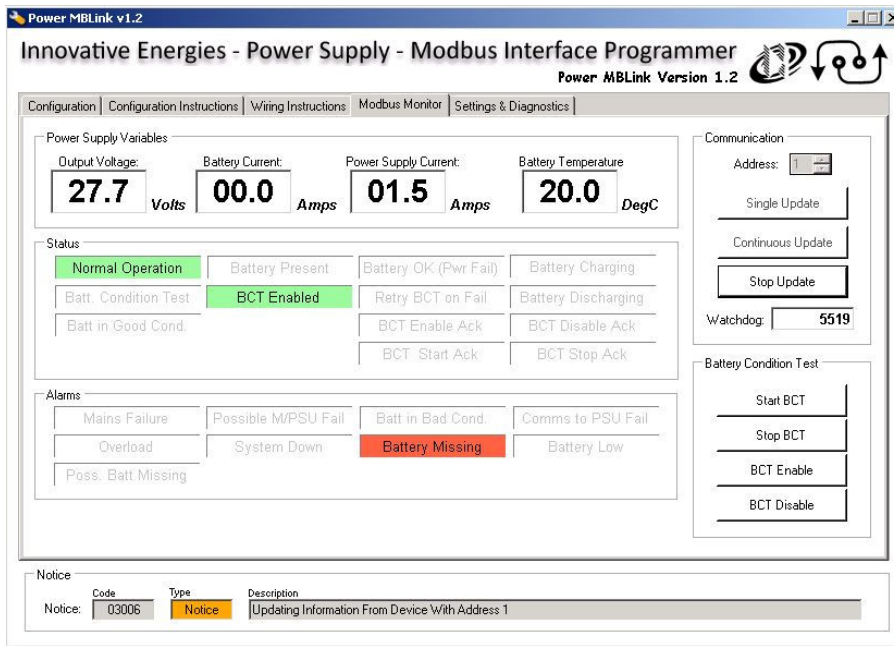

Typical screen shot using Modbus protocol converter

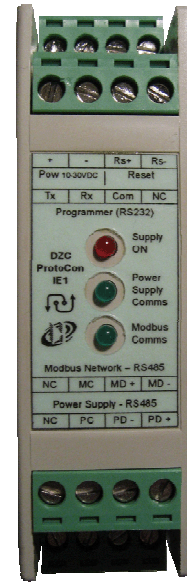

Optional protocol converter

ALARM CONDITIONS DISPLAYED

- Mains Failure
- Possible Mains/PSU Fail
- Battery in Bad Condition
- Communications to PSU Fail (eg. on LV disconnect)
- Overload
- System Down
- Battery Missing
- Battery Low
- Possible Battery Missing

COMMAND FUNCTIONS

- BCT Enable
- BCT Disable
- BCT Start
- BCT Stop

OPTIONS

Communication Protocols available from PSU/charger

RS485, RS232, LAN versions transmit IE proprietary ASCII code.
LAN+ version is SNMP compatible

Modbus Protocol Converter

Protocol Converter for use with comms. output from PSU, with programming port for PC & Modbus compatible output. **Power MBLink** setup software included.

Modbus protocol versions available:

- RTU
- TCP/IP

Codes: **+PROTOCOLNMB**: supports Modbus RTU on RS485 link

+PROTOCOLNMB-OE: supports Modbus RTU on RS485 or RS232 link and Modbus TCP/IP over ethernet

MODEL CODING AND SELECTION CHART

SR250 i 12 T F S L 485

Optional Communications Interface Port 485 = RS485 232 = RS232 LAN = Ethernet (ASCII) LAN+ = Ethernet (SNMP)

