

LPI-D DC Transmitter.

Isolating DC Signal Input
to 4~20mA Output
Loop Powered Transmitter.

Features.

- Field Programmable Bi-Polar Input Ranges.
- Isolated Input to Output 2.0kV.
- High Accuracy.
- 40~200mV Output Test Signal.
- LED Indication of Loop Current.
- Selectable 3 Second Damping.
- Low Cost.
- Easy to Install.
- Compact DIN Rail Mount Enclosure.
- Available Standard or Special Calibration.
- Reverse Polarity Protection.



Other LPI- models include:
LPI-B :Bridge / Strain gauge;
LPI-F :Frequency;
LPI-K :Resistance;
LPI-N :Differential Pt100 RTD;
LPI-P :Potentiometer;
LPI-R :Pt100 RTD;
LPI-T :Thermocouple.
LPI-DO2 :DO2, LCD Display;
LPI-ORP :ORP, LCD Display;
LPI-pH :pH, LCD Display.

Ordering Information.

LPI-D-F-X Standard 4~20mA Fixed Input Range Calibration.

LPI-D-F--Special Range Special Fixed Input Range Calibration.
IR

LPI-D-P-X Standard 4~20mA Input, Programmable Input Range Calibration.

LPI-D-P--Special Range Special Programmable Input Range Calibration.
IR

INPUT RANGES			
Voltage	IR	Current	IR
0~10mV	A	0~200µA	1
0~20mV	B	0~500µA	2
0~50mV	C	0~1mA	3
0~100mV	D	0~2mA	4
0~200mV	E	0~5mA	5
0~500mV	F	0~10mA	6
0~1V	G	0~20mA	7
0~2V	H	0~40mA	8
0~4V	I	0~50mA	9
0~5V	J	1~5mA	10
0~10V	K	2~10mA	11
0~20V	L	4~20mA	12
0~50V	M	10~50mA	13
0~100V	N	-1~1mA	14
0~150V	O	-10~10mA	15
1~2V	P	-20~20mA	16
1~5V	Q	20~4mA *	17
2~10V	R	50~10mA *	18
-1~1V	S		
-5~5V	T		
-10~10V	U		
Special Input Range			Z

Ranges with '*' beside them must have the polarity of their connections reversed.

Ordering Examples.

LPI-D-F-Q LPI-D; Fixed Input Range; 1~5V Input; Loop Powered 4~20mA Output.

LPI-D-P-3 LPI-D; Programmable Input Range; 0~1mA Input; Loop Powered 4~20mA Output.

Quality Assurance Programme.

The modern technology and strict procedures of the ISO9001 Quality Assurance Programme applied during design, development, production and final inspection grant the long term reliability of the instrument.

LPI-D Specifications.

Input	-Voltage	10mVdc to 150Vdc and Bipolar. (LPI-D-P is Field Programmable.) Minimum Input Resistance = 200k Ω . Maximum Over-range = 170Vdc Continuous.
	-Current	200 μ A dc to 100mA dc and Bipolar. (LPI-D-P is Field Programmable.) Input Resistance = 25 Ω . Maximum Overrange = 120mA dc Continuous.
	-Damping	3 Second Selectable with H1. (LPI-D-P Only)
Output	-mA	2 wire 4~20mA. (Loop Powered.)
	-mV Test	40~200mV \pm 1% @ 4~20mA. Other Test Voltages Available. e.g. 1~5V. Note. mV Test Increases Power Supply & Decreases Load Resistance.
Power Supply		8~33Vdc.
Supply Voltage Sensitivity		< \pm 0.005%/V FSO.
Output Load Resistance		800 Ω @ 24Vdc. (50 Ω /V Above 8Vdc.)
Maximum Output Current		Limited to <28mA.
-		
Accurate to		< \pm 0.1% FSO Typical.
Linearity & Repeatability		< \pm 0.1% FSO Typical.
Ambient Drift		< \pm 0.02%/C FSO Typical.
Noise Immunity		125dB CMRR Average. (2.0kVac RMS Limit.)
EMC Compliances		Emissions EN 55022-A. Immunity EN 50082-1, <1% Effect FSO Typical.
Isolation Test Voltages		2000Vac/dc Input to Output for 1min.
Response Time		200msec Typical. (10 to 90% 50msec Typical.)
Operating Temperature		0~70C.
Storage Temperature		-20~80C.
Operating Humidity		5~85%RH Max. Non-Condensing.
Dimensions and Construction		L=79, W=22.5, H=85mm. Polyamide Thermoplastic Rail Mount Enclosure.

Product Liability. This information describes our products. It does not constitute guaranteed properties and is not intended to affirm the suitability of a product for a particular application. Due to ongoing research and development, designs, specifications, and documentation are subject to change without notification. Regrettably, omissions and exceptions cannot be completely ruled out. No liability will be accepted for errors, omissions or amendments to this specification. Technical data are always specified by their average values and are based on Standard Calibration Units at 25C, unless otherwise specified. Each product is subject to the 'Conditions of Sale'.

Warning: These products are not designed for use in, and should not be used for patient connected applications. In any critical installation an independent fail-safe back-up system must always be implemented.

Examples of Input Connection.

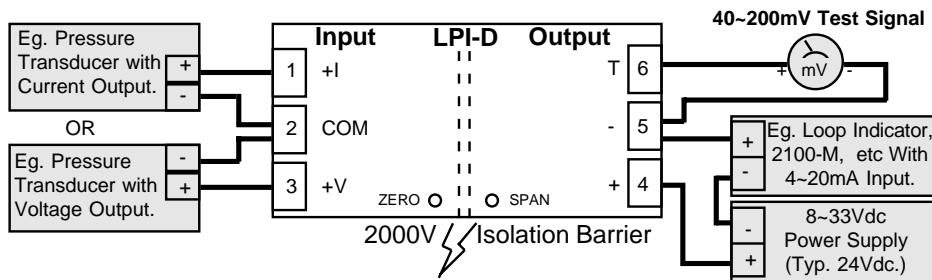

Terminations.

Input	1	+I
	2	COM
	3	+V
Output	4	+mA
	5	-mA
	6	mV TEST

Enclosure Dimensions.

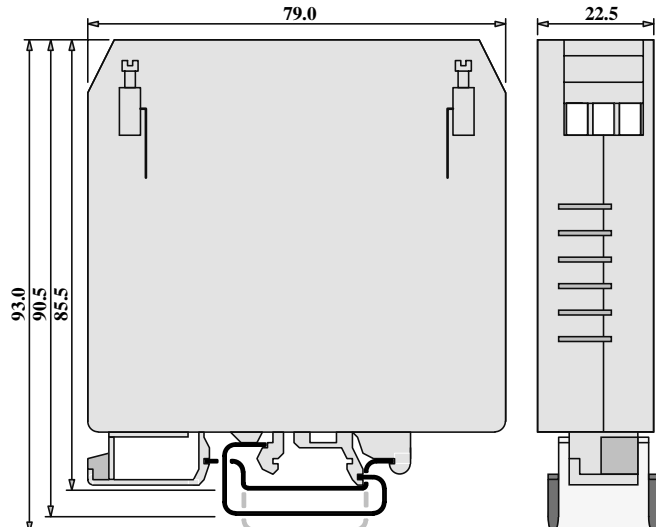

Maximum Load Vs Power Supply.

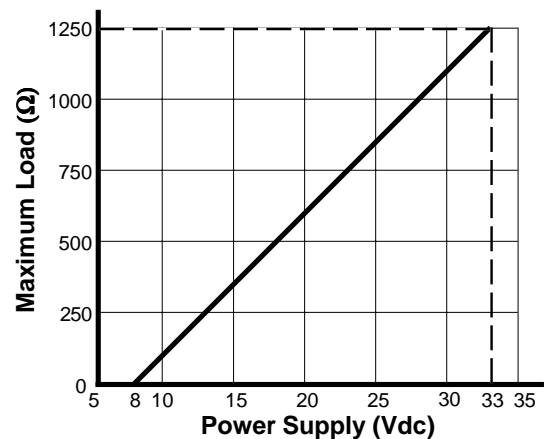

LPI-D-P Input Programming.

LPI-D-P ONLY

If the input range is not listed in the programming table, use the following formulae to work out the Zero and Span DIP switch settings for gain.

$$\text{Span Gain} = \frac{24}{\text{Pregain} \times (\text{Signal High} - \text{Signal Low})}$$

$$\text{Zero Gain} = 10 \times \text{Pregain} \times \text{Signal Low.}$$

If Zero is
1/ Positive, put S3-4 OFF.

2/ Negative, put S3-4 ON.

Notes: (a) Enter ranges with their exponential value.

Eg. Enter 20mA as 20×10^{-3} .

Enter 100mV as 100×10^{-3} .

(b) Use the same pregain value in both the Span and Zero gain formulae.

(c) Enter the Zero or Span gain value into the appropriate Zero or Span DIP switch.

(d) If your **GAIN ZERO** exceeds **63**, then your input range will need to be factory calibrated.

		EFFECTIVE INPUT RANGE (ie Signal High - Signal Low)	S3-1	S3-2	S3-3	PREGAIN
VOLTAGE INPUT		10mV <= Range <= 20mV	0	0	0	200
		20mV < Range <= 200mV	0	0	1	20
		200mV < Range <= 2V	0	1	1	2
		2V < Range <= 20V	1	0	1	0.2
		20V < Range <= 150V	1	1	1	0.02
CURRENT INPUT		200µA <= Range <= 800µA	1	0	0	5000
		800µA < Range <= 8mA	1	0	1	500
		8mA < Range <= 50mA	1	1	1	50

Gain Value	1	2	4	8	16	32
DIP Switch No.	1	2	3	4	5	6

So if a gain value of 28 is required, put DIP switch No's 3, 4, 5

(ie, gains of $4 + 8 + 16 = 28$) OFF and all the other DIP switches ON.

Dip switches are accessed by seperating the two halves of the LPI-D enclosure.

LPI-D-P Input Range Programming Table.

Notes: 1/ Switch status 1 = ON, 0 = OFF, X = DON'T CARE.

2/ Input ranges with '*' beside them reverse the polarity of the input connections.

3/ Input ranges with '#' beside them require more adjustment with the Zero and Span trimpots.

Input Range	S1-ZERO						S2-SPAN						S3-FUNCTION			
	1	2	3	4	5	6	1	2	3	4	5	6	1	2	3	4
0~10mV	1	1	1	1	1	1	1	1	0	0	1	1	0	0	0	x
0~20mV	1	1	1	1	1	1	1	0	0	1	1	1	0	0	0	x
0~50mV	1	1	1	1	1	1	1	1	1	0	0	1	0	0	1	x
0~100mV	1	1	1	1	1	1	1	1	0	0	1	1	0	0	1	x
0~200mV	1	1	1	1	1	1	1	0	0	1	1	1	0	0	1	x
0~500mV	1	1	1	1	1	1	1	1	1	0	0	1	0	1	1	x
0~1V	1	1	1	1	1	1	1	1	0	0	1	1	0	1	1	x
0~2V	1	1	1	1	1	1	1	0	0	1	1	1	0	1	1	x
0~4V	1	1	1	1	1	1	1	0	0	0	0	1	1	0	1	x
0~5V	1	1	1	1	1	1	1	1	1	0	0	1	1	0	1	x
0~10V	1	1	1	1	1	1	1	1	0	0	1	1	1	0	1	x
0~20V	1	1	1	1	1	1	1	0	0	1	1	1	1	0	1	x
0~50V	1	1	1	1	1	1	1	1	1	0	0	1	1	1	1	x
0~100V	1	1	1	1	1	1	1	1	0	0	1	1	1	1	1	x
0~150V	1	1	1	1	1	1	1	1	1	0	1	1	1	1	1	x
1~5V	1	0	1	1	1	1	1	0	0	0	0	1	1	0	1	0
2~10V	1	1	0	1	1	1	1	0	0	0	1	1	1	0	1	0
-1~1V	1	1	0	1	0	1	1	0	0	1	1	1	0	1	1	1
-5~5V	1	0	1	0	1	1	1	1	1	0	0	1	1	0	1	1
-10~10V	1	1	0	1	0	1	1	0	0	1	1	1	1	0	1	1
0~200µA	1	1	1	1	1	1	1	1	1	0	0	1	1	0	0	x
0~500µA#	1	1	1	1	1	1	1	0	1	0	1	1	1	0	0	x
0~1mA	1	1	1	1	1	1	1	1	1	1	0	0	1	0	1	x
0~2mA	1	1	1	1	1	1	1	1	1	0	0	1	1	0	1	x
0~5mA#	1	1	1	1	1	1	1	0	1	0	1	1	1	0	1	x
0~10mA	1	1	1	1	1	1	1	1	1	1	0	0	1	1	1	x
0~20mA	1	1	1	1	1	1	1	1	1	0	0	1	1	1	1	x
0~40mA	1	1	1	1	1	1	1	1	0	0	1	1	1	1	1	x
0~50mA#	1	1	1	1	1	1	1	0	1	0	1	1	1	1	1	x
1~5mA	0	1	0	1	1	1	1	1	1	0	0	1	1	0	1	0
2~10mA	1	0	1	0	1	1	1	0	0	1	1	1	1	0	1	0
4~20mA	1	0	1	1	1	1	1	0	0	0	0	1	1	1	1	0
10~50mA	0	1	0	1	1	1	1	1	1	0	0	1	1	1	1	0
-1~1mA	0	1	0	1	1	1	1	1	1	1	0	0	1	0	1	1
-10~10mA	0	1	0	1	1	1	1	1	1	1	0	0	1	1	1	1
-20~20mA	1	0	1	0	1	1	1	1	1	0	0	1	1	1	1	1
* 20~4mA	1	0	1	0	1	1	1	1	0	0	0	0	1	1	1	1
* 50~10mA	0	1	1	0	0	0	1	1	1	0	0	1	1	1	1	1

Plan View of LPI-D-P Adjustments.

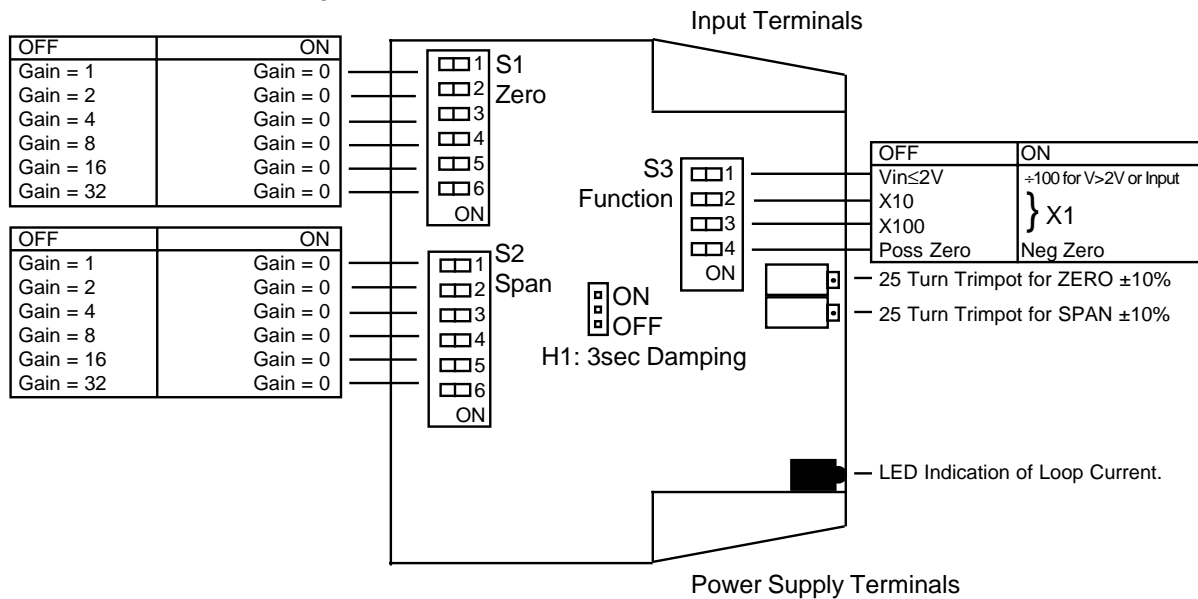

The Proper Installation & Maintenance of LPI-D.

All power and signals must be de-energised before connecting any wiring, or altering any Jumpers or Dip Switches.

MOUNTING.

- (1) Mount in a clean environment in an electrical cabinet on DIN or EN mounting rail.
- (2) Draft holes must have minimum free air space of 20mm. Foreign matter must not enter or block draft holes.
- (3) Do not subject to vibration or excess temperature or humidity variations.
- (4) Avoid mounting in cabinets with power control equipment.
- (5) To maintain compliance with the EMC Directives the LPI-D is to be mounted in a fully enclosed steel cabinet. The cabinet must be properly earthed, with appropriate input / output entry points and cabling.

WIRING.

- (1) All cables should be good quality overall screened INSTRUMENTATION CABLE with the screen earthed at one end only.
- (2) Signal cables should be laid a minimum distance of 300mm from any power cables.
- (3) For 2 wire current loops and 2 wire voltage signals or 2 wire current signals, Austral Standard Cables B5102ES is recommended. For 3 wire transmitters Austral Standard Cables B5103ES is recommended.
- (4) It is recommended that you do not ground current loops and use power supplies with ungrounded outputs.
- (5) Lightning arrestors should be used when there is a danger from this source.
- (6) Refer to diagrams for connection information.

COMMISSIONING.

- (1) Once all the above conditions have been carried out and the wiring checked apply power to the LPI-D loop and allow five minutes for it to stabilize.
- (2) Take a low (approx 10%) and high (approx 90%) reading of the variable being measured by the transducer supplying the signal to the LPI-D, and ensure that this agrees with the level being indicated by the PLC or indicator, etc, that the LPI-D is connected into. Adjust for any difference using the Zero & Span Pots in the top of the LPI-D enclosure with a small screw driver, until the two levels agree. (Clockwise to increase the output reading and anti-clockwise to decrease the output reading.)

MAINTENANCE.

- (1) Repeat (2) of Commissioning.
- (2) Do it regularly - at least once every 12 months.